

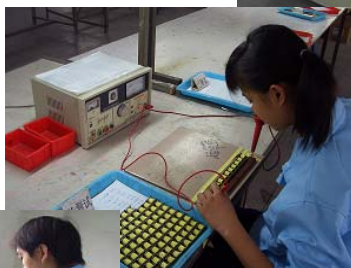

**Shengda**  
*Electronics*

**安德实业(香港)有限公司**  
Ande Industrial (HK) Co., Ltd.  
**东莞市东城盛达电子厂**  
Shengda Electorronics(Guangguan) Co., Ltd.

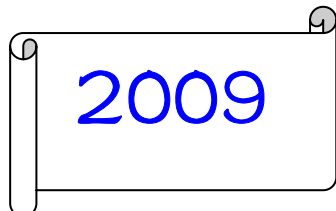

Tel: +86-(769)-2316-0561

Fax: +86-(769)-2316-0532

E-mail: [bill.gao@vip.163.com](mailto:bill.gao@vip.163.com)

Mobile: (0)13560872211

工厂地址: 广东省东莞市东城区峡口管理区榴花西街横一卷5号(P.C:523115)

ADD: Xiakou industrial Area, Dongcheng District ,Dongguan ,Guangdong, PRC .

盛达电子座落于中国电子工业重镇，中国著名台资投资区-广东省东莞市，是一家专业电脑主板厂商及电源类产品配套供应企业。

本公司集研发-生产-销售-贸易为一体，具有良好的研發與設計能力，具有十数年專業電源類產品工作经验的工程师通力协作，根据您各种不同的需求设计并制造出不同类型的产品，满足您的需求。且本公司毗邻品翔、树林、铁研、金圣、钢一、嘉成、居磁、飞磁等企业，故能以最快的速度取得原材料，加之公司全體員工對產品品質的嚴格要求，以致我們能以優良的品質和專業的服務得到客戶的最大滿意。

与此同时，公司建立了一整套完善的管理模式及质量保证体系，并在2008年通过ISO9001:2000的认证，以可靠的质量保证来服务于客户。

Shengda Electronics (Dongguan)Co.,Ltd is a professional electronic componen manufacturer .We provide the professional related fittings products for all the comput mother board and electric power supply enterprises .It reposes in one of the important electronic and industrial town of China --Dongguang City in Guangdong,which is a famous Taiwan dealer investing district.

Our company assembles prodcution -sales -trade together ,we are able to develop and design all kinds of different products according to our customers'demand, and e provid the best indevelopment ,delivery,quality and price for our customers.Addition our company is adjacent to the famous components enterprise ,such as Pinshine,Shu TAK,Shensheng,Qangyi,Karson,Curie,Ferroxcube ect.So we can get the material at first time.And we have the professional power experts worked together for custome service, so we can provide the best quality and professional service to meet custom satisfy.

Meanwhile the company is operating under superior management system and quality assurance system.In 2008 ,ISO9001:2000 certificate have been issued.We will provide the best service because of the relibable quality products.

**我們的承諾：**

**急客戶所急， 想客戶所想！**

**為客戶提供優質地產品與服務！**

Tel: +86-(769)-2316-0561

Fax:+86-(769)-2316-0532

E-mail: [bill.gao@vip.163.com](mailto:bill.gao@vip.163.com)

Mobile:(0)13560872211

工厂地址：广东省东莞市东城区峡口管理区榴花西街横一巷5号(P.C:523115)

ADD: Xiakou industrial Area, Dongcheng District ,Dongguan ,Guangdong, PRC

## 经营理念：

通过世界级的运作, 为客户提供优质的具有竞争价格的产品或服务.

## 质量政策：

品质第一, 用户至上.  
精诚协作, 持续改善.

## 质量总目标：

客户满意度  $\geq 90\%$   
交期达成率  $\geq 98\%$

东莞市东城盛达电子厂示

2008 年 03 月 20 日

## Power Inductors-THT Toroidal



- ◆ For use in high frequency DC/DC converters
- ◆ Low radiation
- ◆ Low core loss
- ◆ Current handling up to 50 Amps

### MECHANICAL SPECIFICATIONS

Front View

Side View

PCB Layout(Top)

Schematic

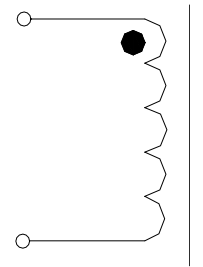
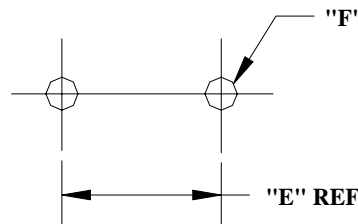
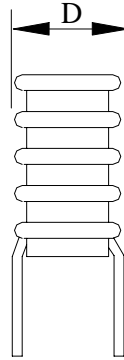
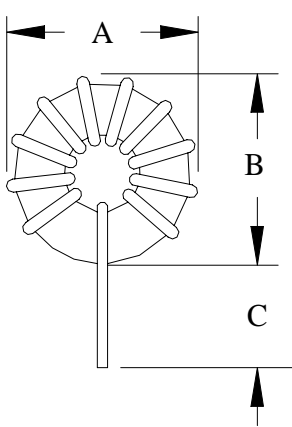

### ELECTRICAL SPECIFICATIONS

- ◆ Core size from 7 to 18mm of outer diameter with different permeabilities
- ◆ Inductance value from 0.13 uH to 10mH
- ◆ Current ranges from 4 to 50 amps
- ◆ Very high energy storage up to 1700 micro-Joules
- ◆ Temperature rise is 40°C typ
- ◆ Operating Temp. rang -40°C to +105°C .

Tel: +86-(769)-2316-0561

Fax: +86-(769)-2316-0532

E-mail: [bill.gao@vip.163.com](mailto:bill.gao@vip.163.com)

Mobile: (0)13560872211

工厂地址: 广东省东莞市东城区峡口管理区榴花西街横一巷5号(P.C:523115)

ADD: Xiakou industrial Area, Dongcheng District ,Dongguan ,Guangdong, PRC

## Power Inductors-THT Square



- ◆ For use in high frequency DC/DC converters
- ◆ Low radiation
- ◆ Low core loss
- ◆ Current handing up to 50 Amps

### MECHANICAL SPECIFICATIONS

Front View

Side View

PCB Layout(Top)

Schematic

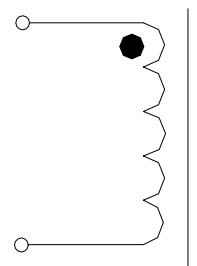
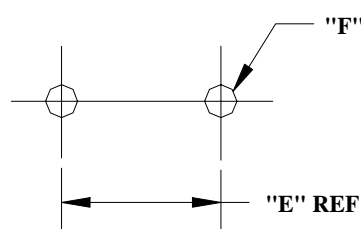
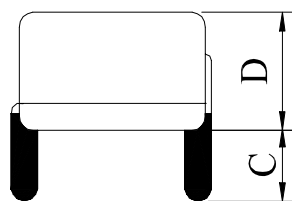
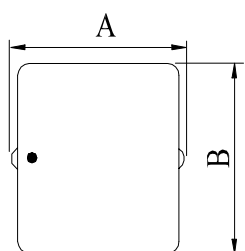

### ELECTRICAL SPECIFICATIONS

- ◆ Inductance value from 0.2 uH to 10uH
- ◆ Current ranges from 4 to 50 amps
- ◆ Very high energy storage up to 1700 micro-Joules
- ◆ Temperature rise is 40°C typ
- ◆ Operating Temp. rang -40°C to +105°C .

Tel: +86-(769)-2316-0561

Fax:+86-(769)-2316-0532

E-mail: [bill.gao@vip.163.com](mailto:bill.gao@vip.163.com)

Mobile:(0)13560872211

工厂地址: 广东省东莞市东城区峡口管理区榴花西街横一巷5号(P.C:523115)

ADD: Xiakou industrial Area, Dongcheng District ,Dongguan ,Guangdong, PRC .

## Power Inductors-THT R Core



- ◆ Use for Input/Output filtering on switching regulator devices and power supplies
- ◆ Handle upto 15 Amps rms
- ◆ Custom inductance values are available

### MECHANICAL SPECIFICATIONS

Front View

Side View

PCB Layout(Top)

Schematic

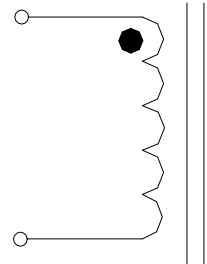
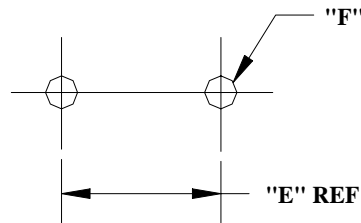
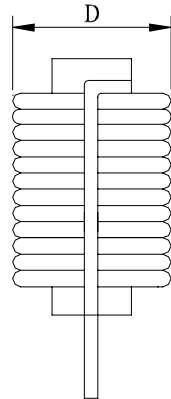
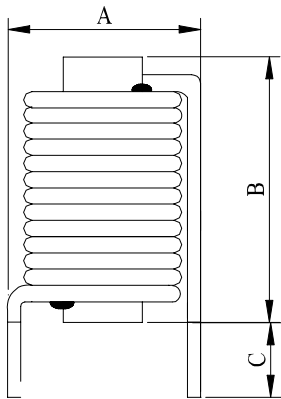

### ELECTRICAL SPECIFICATIONS

- ◆ Core size from 3 to 22mm of outer diameter with different permeabilities
- ◆ Inductance from 1uH to 10uH
- ◆ Handle up to 15 Amps rms
- ◆ Ideal for filtering in switch mode power supplies
- ◆ Temperature rise is 40°C typ
- ◆ Operating Temp. range -40°C to +85°C

Tel: +86-(769)-2316-0561

Fax: +86-(769)-2316-0532

E-mail: [bill.gao@vip.163.com](mailto:bill.gao@vip.163.com)

Mobile: (0)13560872211

工厂地址: 广东省东莞市东城区峡口管理区榴花西街横一卷5号(P.C:523115)

ADD: Xiakou industrial Area, Dongcheng District, Dongguan, Guangdong, PRC.

## Power Inductors-SMD Unshield



- ◆ For use in high frequency DC/DC converters
- ◆ Low DC resistance
- ◆ Stable inductance for increasing current
- ◆ Energy storage of 500 micro-Joules from 2cm<sup>3</sup>

### MECHANICAL SPECIFICATIONS

Front View

Side View

PCB Layout(Top)

Schematic

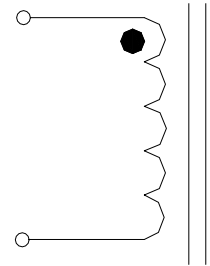
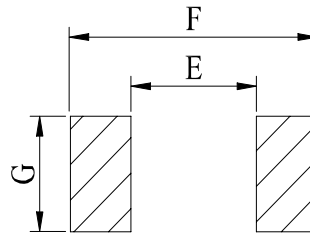
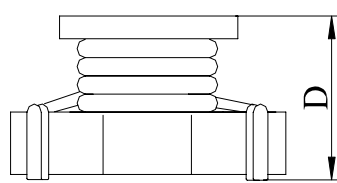
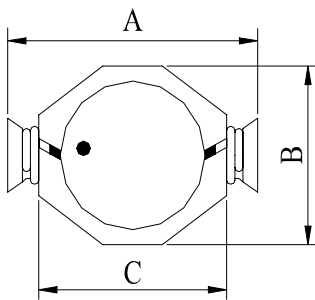

### ELECTRICAL SPECIFICATIONS

- ◆ Core shapes include drum types from 2.9mm to 8.0mm heights
- ◆ Current ranges from 90 milliamperes to 15 amperes
- ◆ Inductance values from 0.33uH to 2.2mH
- ◆ Temperature rise is 30°C typ
- ◆ Indutance drop 10% typ at I sat
- ◆ Operating Temp. range -40°C to +85°C

Tel: +86-(769)-2316-0561

Fax:+86-(769)-2316-0532

E-mail: [bill.gao@vip.163.com](mailto:bill.gao@vip.163.com)

Mobile:(0)13560872211

工厂地址：广东省东莞市东城区峡口管理区榴花西街横一卷5号(P.C:523115)

ADD: Xiakou industrial Area, Dongcheng District ,Dongguan ,Guangdong, PRC .

## Power Magnetics-Transformers



- ◆ Switch mode power supply transformers for fayback, forward,push-pull,halfand full bridge topologies
- ◆ Operating frequencies from 20KHz to 500KHz
- ◆ Wide range of core/bobbin size available for all topologies
- ◆ Power ratings from 0.5VA to 1KVA
- ◆ EMI suppression reduced by shielding construction

### MECHANICAL SPECIFICATIONS

Front View

Side View

PCB Layout(Top)

Schematic

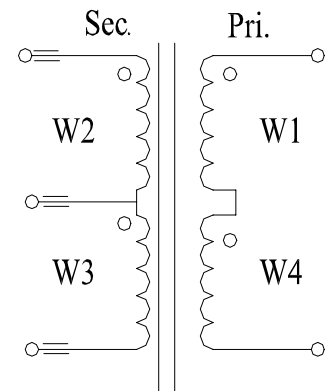
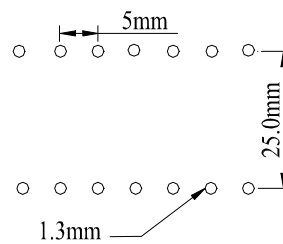
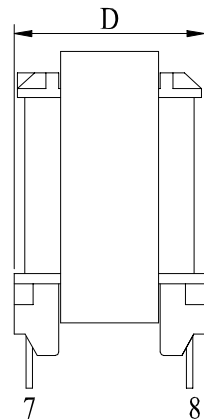
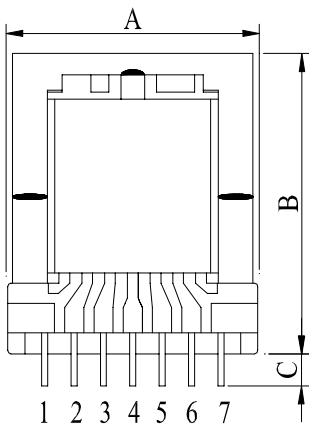

### OVERVIEW

- ◆ Wide input voltage range
- ◆ Efficiency up to 99%
- ◆ Reduced weight and volume
- ◆ Requires extra external components for loop control and switching
- ◆ Excellent load and line regulation
- ◆ Space benefit as output power increases
- ◆ Moderated total cost
- ◆ Big variety of transformers core size and shapes

Tel: +86-(769)-2316-0561

Fax:+86-(769)-2316-0532

E-mail: [bill.gao@vip.163.com](mailto:bill.gao@vip.163.com)

Mobile:(0)13560872211

工厂地址: 广东省东莞市东城区峡口管理区榴花西街横一卷5号(P.C:523115)

ADD: Xiakou industrial Area, Dongcheng District ,Dongguan ,Guangdong, PRC



## Power Inductors-CMC



- ◆ EMI and RFI suppression for switching regulators and power supplies
- ◆ Frequency range: from 1KHz to 500KHz
- ◆ Differential inductance < 1%
- ◆ Current handling up to 25 Amps

### MECHANICAL SPECIFICATIONS

Front View

Side View

PCB Layout(Top)

Schematic

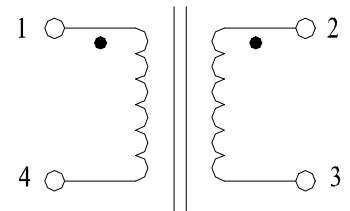
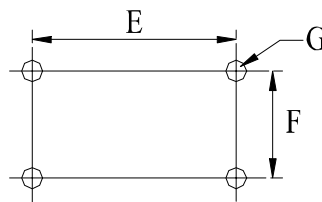
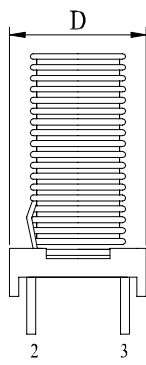
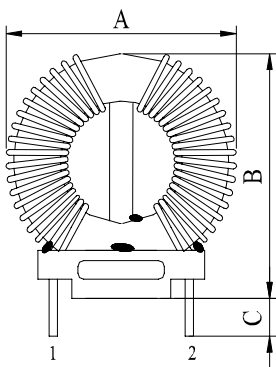

### ELECTRICAL SPECIFICATIONS

- ◆ Standard core shapes: UU, UT, TOROID
- ◆ Inductance range between 5uH to 80mH
- ◆ 1500vrms isolation between winding
- ◆ Temperature rise is 40°C typ
- ◆ Operating Temp. range -40°C to 105°C

Tel: +86-(769)-2316-0561

Fax: +86-(769)-2316-0532

E-mail: [bill.gao@vip.163.com](mailto:bill.gao@vip.163.com)

Mobile: (0)13560872211

工厂地址: 广东省东莞市东城区峡口管理区榴花西街横一巷5号(P.C:523115)

ADD: Xiakou industrial Area, Dongcheng District, Dongguan, Guangdong, PRC.

# Ande

ANDE INDUSTRIAL (HK) Co., Ltd

The design, manufacture and sale of electronics transformer and inductors.

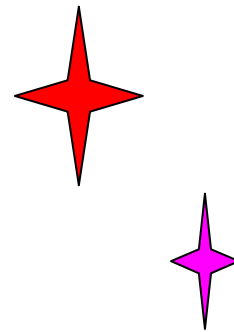

**安德实业(香港)有限公司**

**Ande Industrial (HK) Co., Ltd.**

**东莞市东城盛达电子厂**

**Shengda Electronics(Guangguan) Co., Ltd.**

**Tel: +86-(769)-2316-0561**

**Fax: +86-(769)-2316-0532**

**E-mail: [bill.gao@vip.163.com](mailto:bill.gao@vip.163.com)**

**Mobile: (0)13560872211**

**Web Site: [www.shengdadg.cebiz.cn](http://www.shengdadg.cebiz.cn)**

**公司地址: 香港九龙尖沙咀广东道5号海港城海洋中心10楼1021室**

**UNIT1021,10/F,OCEAN CENTRE,HARBOUR CITY,5 CANTON ROAD,TST,KOWLOON,HK**